

NO.	PART NAME	MATERIAL	Q'ty
1	BODY	CF8M	1
2	INSERT	CF8M	1
3	BALL	CF8M	1
4	BALL SEAT	PTFE	2
5	BODY GASKET	PTFE	1
6	STEM	SS316	1
7	THRUST WASHER	PTFE	1
8	GLAND PACKING	PTFE	1
9	GLAND WASHER	SS304	2
10	SPRING WASHER	SS304	1
11	LOCKING NUT	SS304	1
12	HANDLE	SS304	1
13	GLAND WASHER	VINYL	1

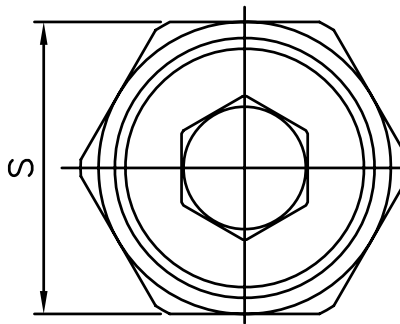
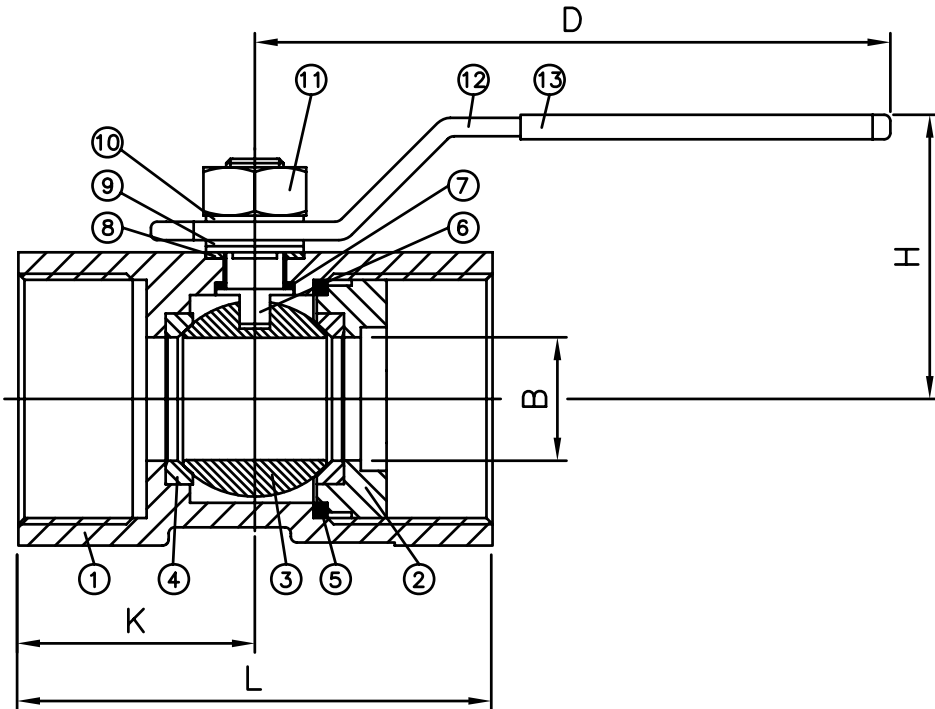

SIZE	øB	L	H	D	K	S
1/4"	5.0	39	36	62.5	19	17
3/8"	7.0	44	38.5	73	21	21
1/2"	9.2	56.5	49	85	27.5	25
3/4"	12.5	59	53.5	87	30	32
1"	16.0	71	54	107	36	38
1-1/4"	20.0	78	59	107	40	49
1-1/2"	25.0	83	68.5	130	42.5	53
2"	32.0	100	71.5	130	51	65

**SUCCESS & SPARKLE CO.,LTD**

TEL : 886-4-2260-0940

FAX : 886-4-2260-0945

501~1000	0.5
101~500	0.2
21~100	0.2
1~20	0.1

TOLERANCE

ISSUE DATE

2009.09.09

MATERIAL

AS TABLE

1-PC BALL VALVE  
THREADED END  
1000 WOG

APPROVE BY

JEFF YU

SCALE

ITEM NO.

S-1

DRAWING BY

LIZ DUNG

UNIT

mm

DRAWING NO.

9B-100850-S